

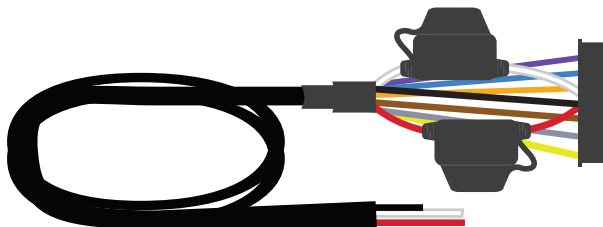

# LMU-2630™

## Installation Guide



Power Harness

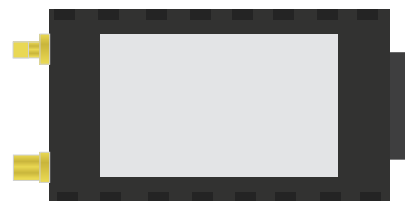

External Antenna

# Mounting the LMU-2630 series

*\*Velcro, double-sided tape, and adhesive not included, but recommended for installation.*

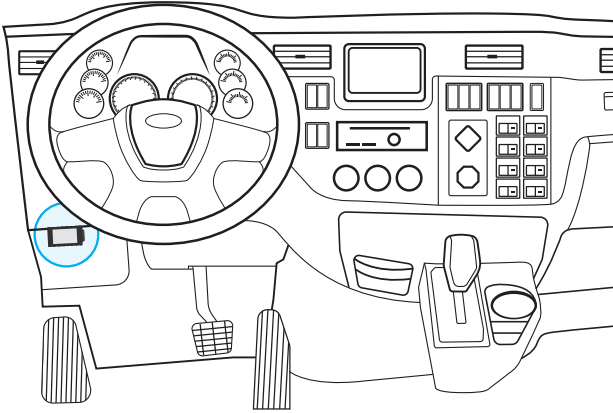

Choose a convenient location in the vehicle's interior, like underneath the dash, to mount the device. Avoid locations that may expose the device to excessive heat or moisture.

## Helpful guidelines

- Affix the device to your chosen location and secure it in place with screws, velcro, or adhesive. The device should be securely set against the mounting surface to ensure stability while the vehicle is in motion.

Please note:

- There should be no metal located above the device, as this may interfere with the GPS signal.
- This device may have an internal battery care disclaimer. Make sure that the unit is kept safe from direct exposure to the elements (sun, heat, rain, moisture, etc.) and away from heater vents or hot engine compartments. Keep the unit away from heat that will produce an internal temperature of or exceeding 140° F.

## Connecting the power harness



Connect the 20 Pin Power Harness connector to the 2630 device.

# Installing the Power/Serial Cable

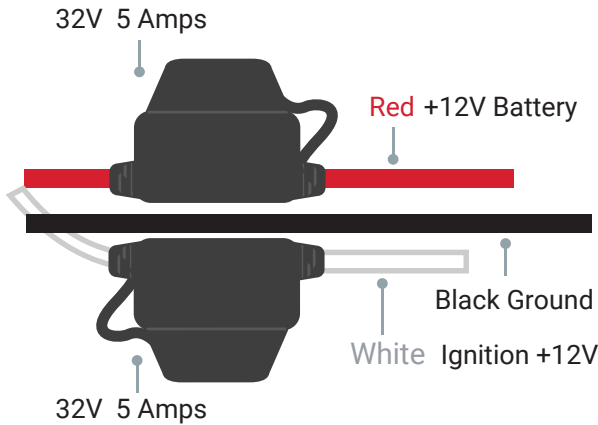

Note: The ignition wire must be connected to the vehicle's ignition and NOT to the battery. Unused wires must be insulated to prevent shorts. Don't use quick taps or leave cut wires exposed.

## Step 1: Red Battery Wire

- Connect red wire to a 12V - 24V power source. Make sure the positive voltage is between 7 and 32 volts.

## Step 2: Black Ground Wire

- Connect ground wire to the vehicle chassis.

## Step 3: White Ignition Wire

Once powered up, the LED indicators (diagram page 3) will show a solid orange light for a cell signal and a solid green for a GPS signal. When the light is blinking, the device is searching for a signal. It may take up to five minutes to get a GPS lock. If you are unable to retrieve a signal after waiting a minute or two, reposition the unit and try again.

Note: It takes 20-60 seconds before the Locator can detect that the SIM card is not properly installed.

Alternatively, a cigarette adapter can be used to power the device. Call 1 (800) 881-6343 for more info.

# LED Diagram

LED	Meaning
Off	The Modem is Off
Solid Green, Solid Orange	Ideal Connection
Slow Orange Blinking	Searching
Fast Orange Blinking	Network Available
Solid Orange	Registering & Receiving Inbound Acknowledgement
Alternating Slow & Fast	Registered but NO Inbound Acknowledgement
Slow Green Blinking	GPS On
Fast Green Blinking	GPS Time Sync
Solid Green	GPS Fix

## Testing Indicators



## Installing the telemetry

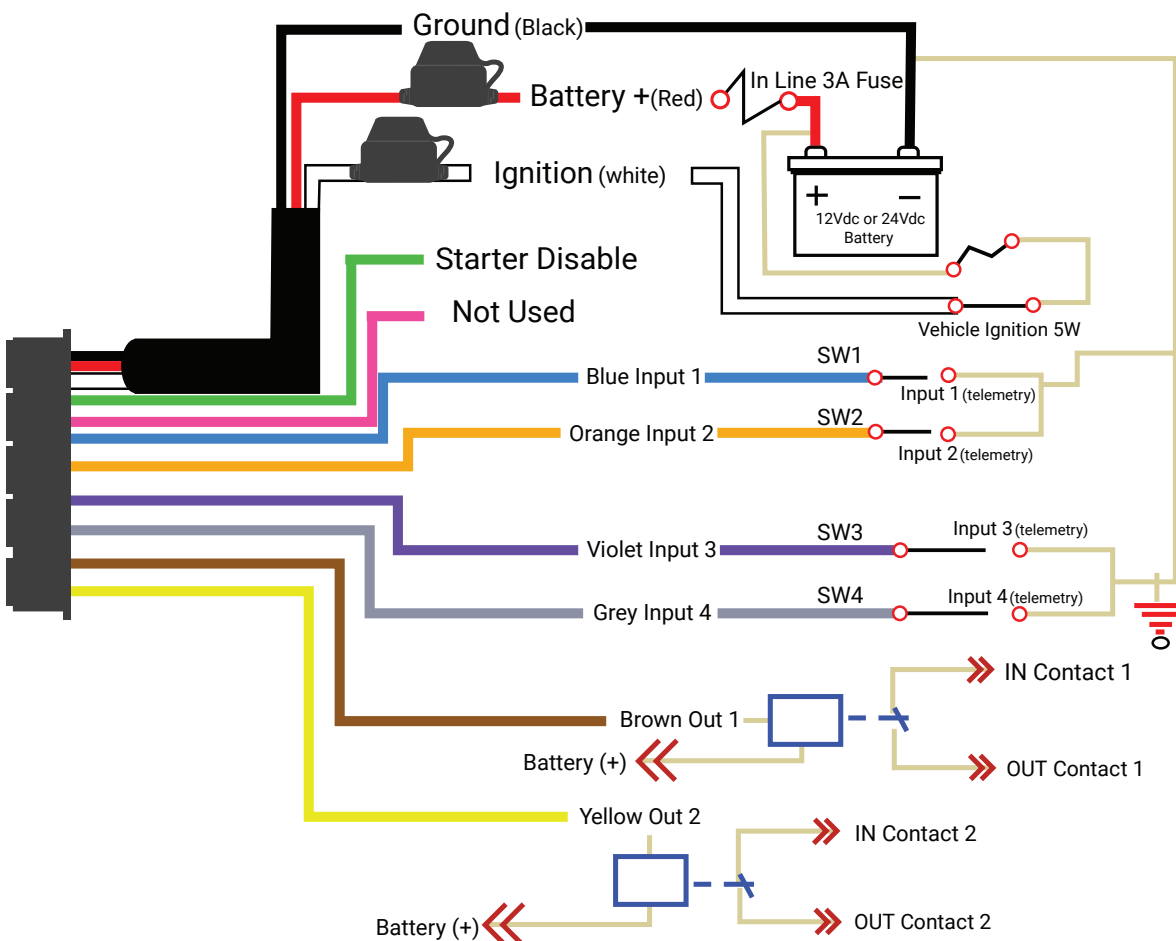

# Accessories for the LMU-2630

## OBDII Diagnostics

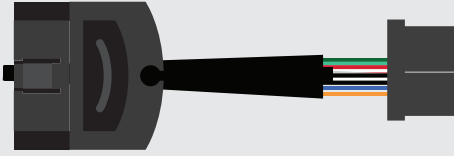

The OBDII Diagnostics adapter cable enables the LMU-2630 to transmit vehicle diagnostics indicators, parameters and engine codes

## J-bus

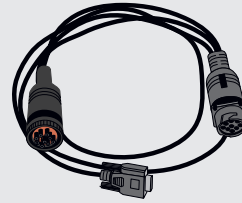

The J-bus Diagnostics adapter Cable Enables the LMU-2630 to transmit vehicle diagnostics indicators, parameters and engine codes

## Temperature Sensors

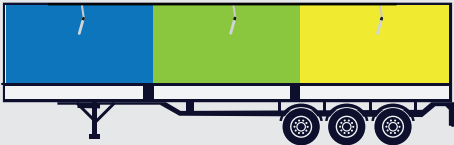

Monitor up to three separate temperature zones in a trailer. Alerts can be configured based on high/low temperature thresholds.

## Starter Disable



Starter disable allows you to remotely immobilize a parked vehicle by preventing it from starting. If activated while vehicle is running it will continue to operate normally until shut-down but will not start again until re-enabled

## Driver ID Kit



The LMU-2630 works in conjunction with a key fob coded with a unique number. The system checks the database and then assigns the driver to the vehicle.

## Driver Buzzer

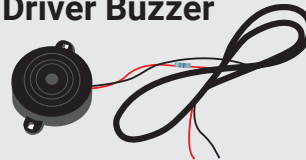

The buzzer delivers audible alerts to drivers. It can be used with Driver ID login and logout reminders or driver behavior alerts.

# Vehicle diagnostics with OBDII adapter

## Mounting the Adapter

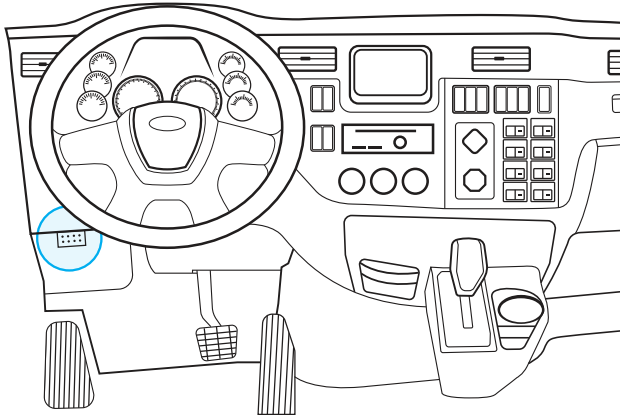

Locate the OBDII Port – Typically found under the dash, near the steering wheel. Insert the adapter into the port until seated. Verify that there is sufficient cable for the adapter to reach the port from the installed 2630 tracking device.

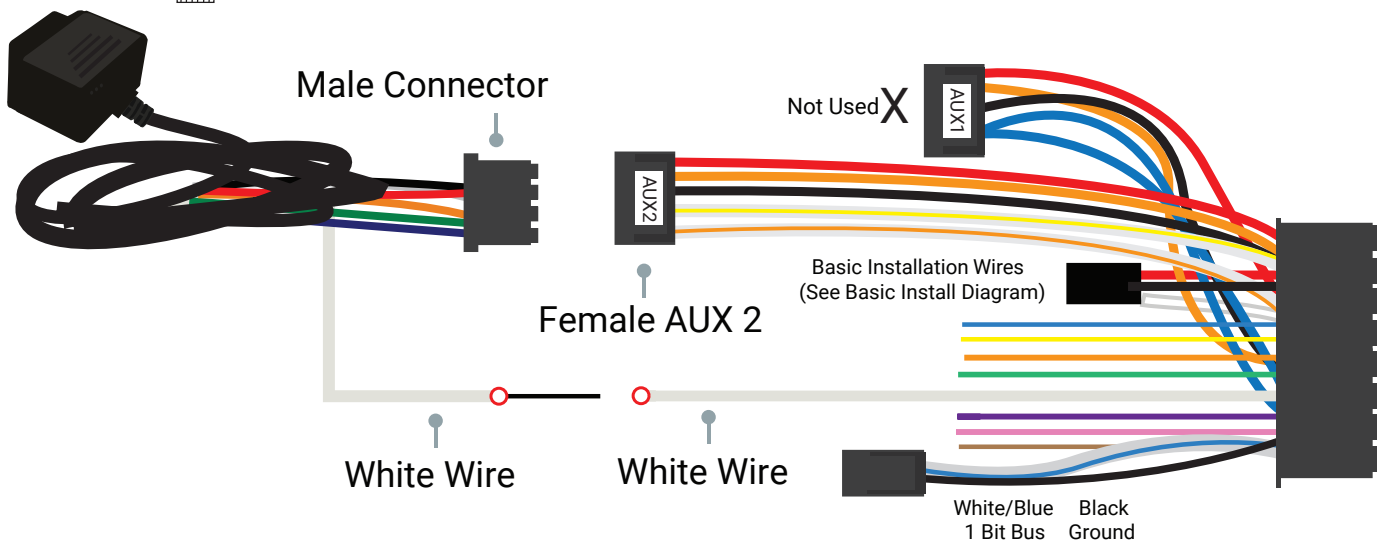

## Connecting the adapter

- Connect the adapter to the tracking device by plugging the male contact of the mini connector into the AUX 2 female port on the wiring harness.
- Connect the White Ignition Wire to the White Wire reserved from installation of the LMU-2630.

Verification of the installation is required by technical support. Once the LMU-2630 device, accessories and integrations have been installed, make sure that the vehicle is outside of parking garages and away from tall buildings, as these may interfere with the GPS signal.

# Mounting JBUS Diagnostics

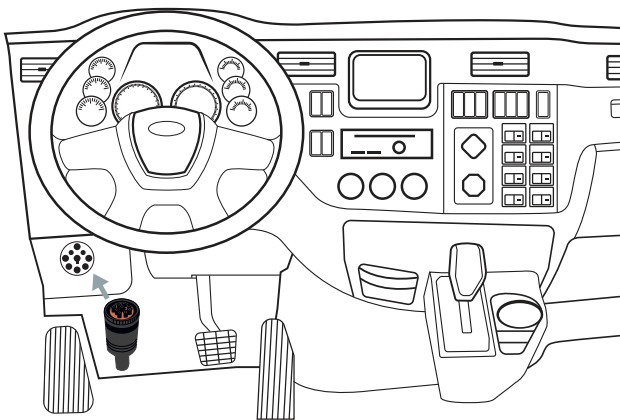
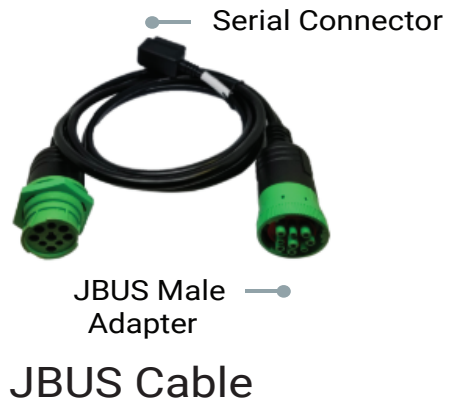
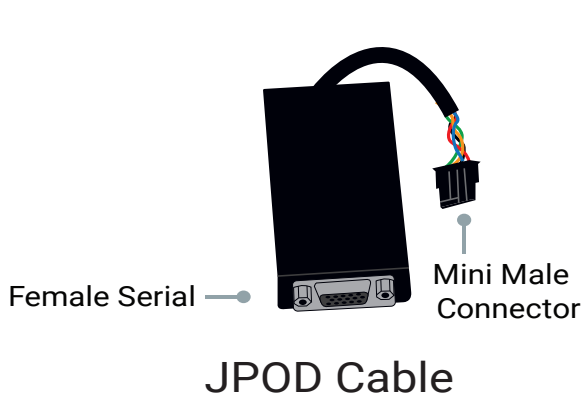

**Locate the JBUS Port in the vehicle**  
 This is typically found under the dash near the steering wheel. Insert the JBUS male adapter into the port until seated.

2. Connect the JPOD to the tracking device by plugging the male contact of the mini connector into the AUX 2 female port on the wiring harness.

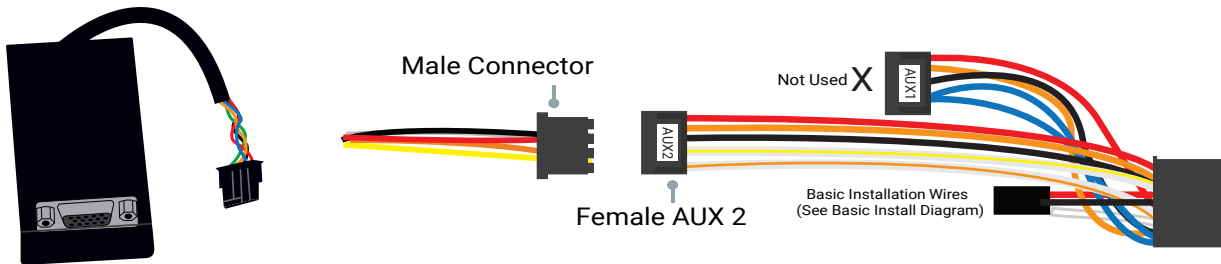

3. Connect the JPOD serial connector to the JBUS serial connector.

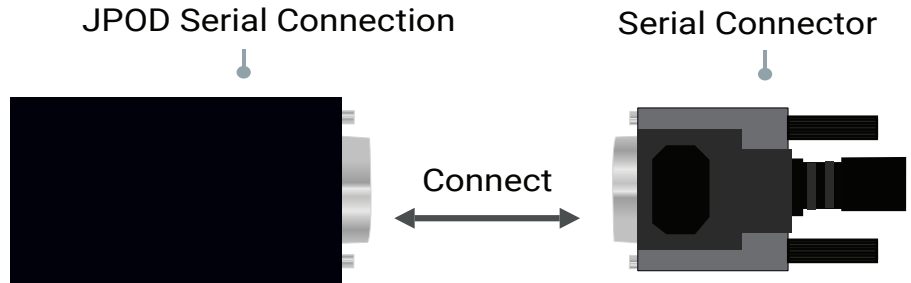

# Temperature sensor

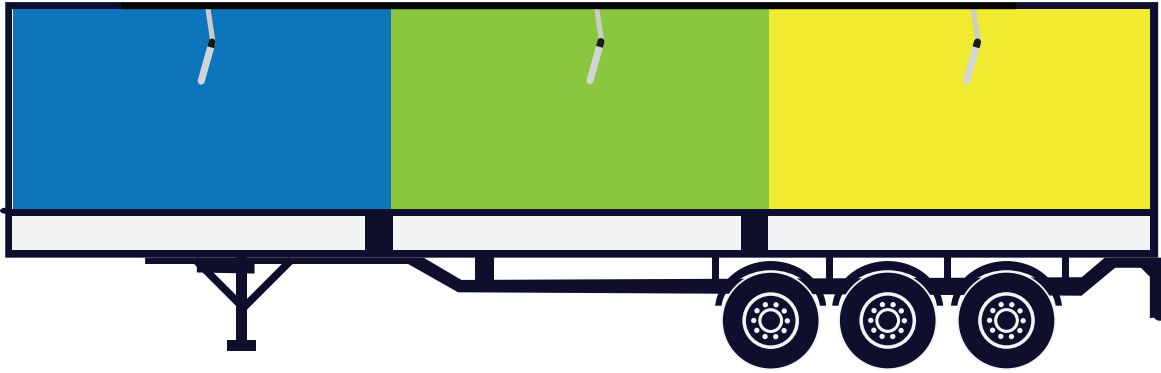

## Mounting the sensor(s)

Determine optimal mounting location(s) for sensor(s). Mount these away from cooling vents and heavily trafficked areas to prevent damage to the sensors.

## Helpful guidelines

- Temperature sensors are typically mounted on the front wall, beside the refrigeration unit and in the center or rear of the trailer.
- Mount on the wall in an area that is exposed to ambient temperature, approximately halfway between the floor and ceiling.
- The orientation of the sensor(s) does not matter.
- Decide where the sensor(s) will be mounted ahead of time and estimate the length of additional standard primary wire required to reach and link these sensor(s).
- Two different lengths and colors of standard primary wire are required for each sensor.
- DO NOT mount on the floor, in the direct flow of a refrigeration unit, or anywhere that may interfere with temperature measurements.

# 4 wire single sensor installation

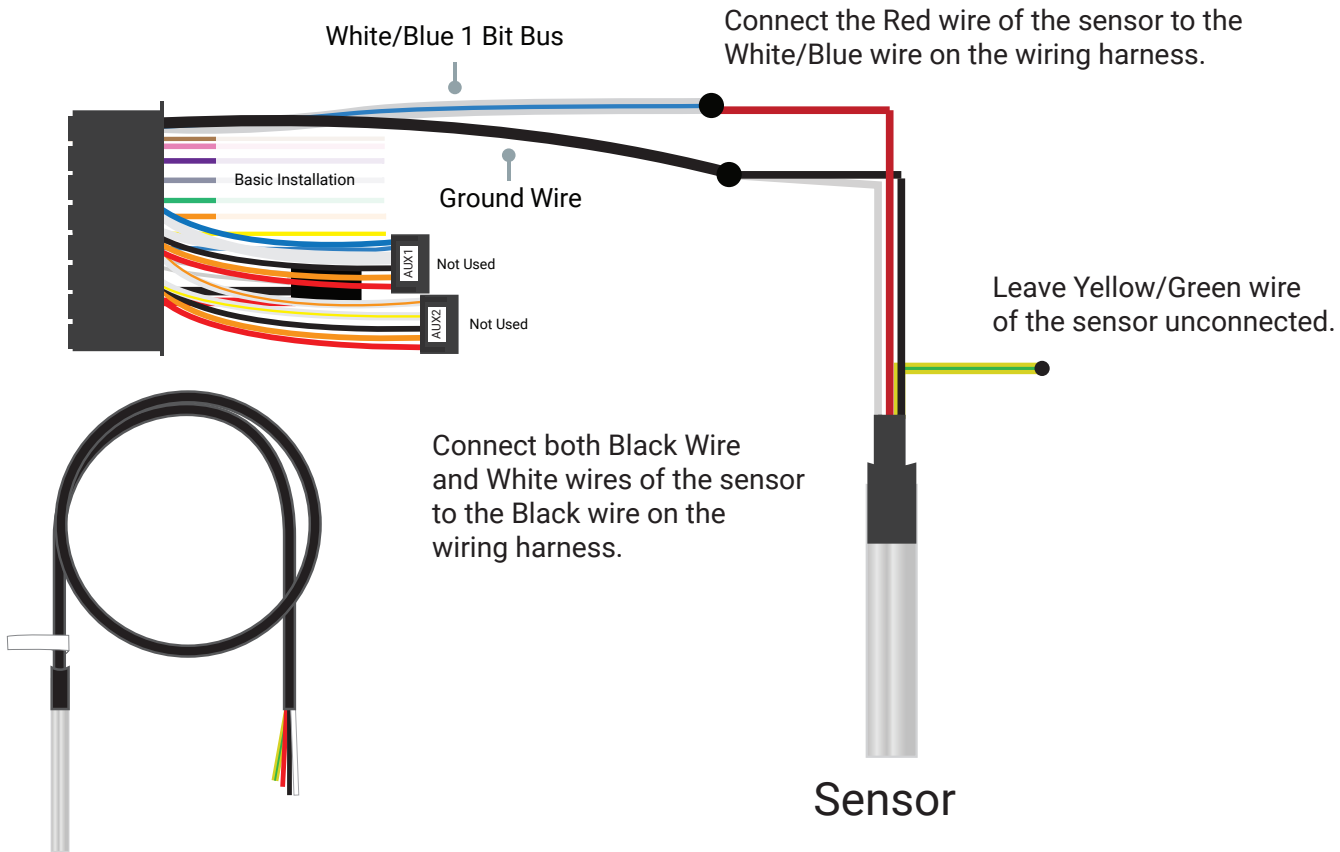

# 4 wire multiple sensor installation

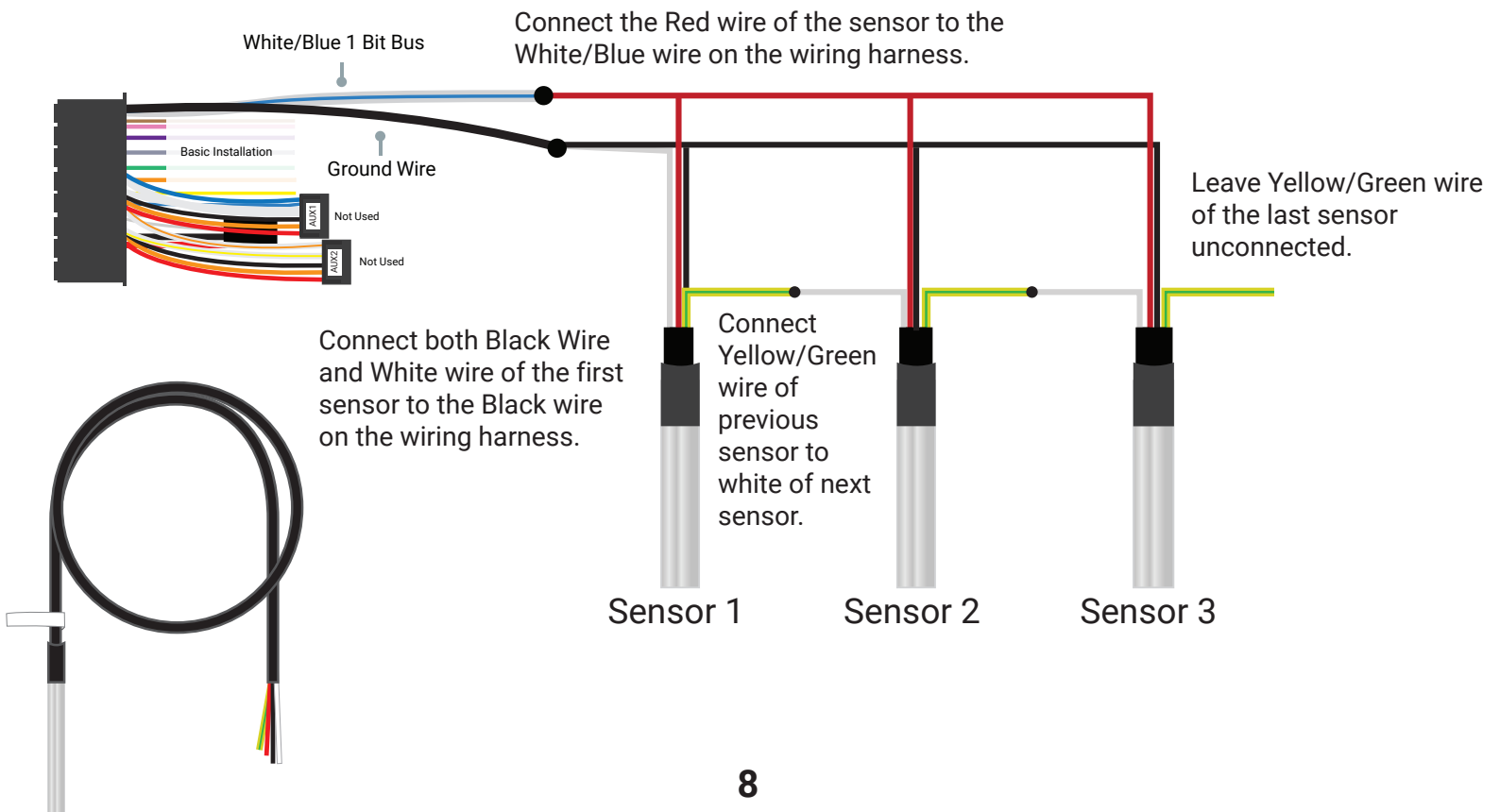

# Optional Starter/Disable installation

Starter Disable goes into effect the next time someone attempts to start the vehicle after successful installation. It remains in effect until the disable command is sent.

Note: Starter Disable will not shut off a vehicle while the engine is running.

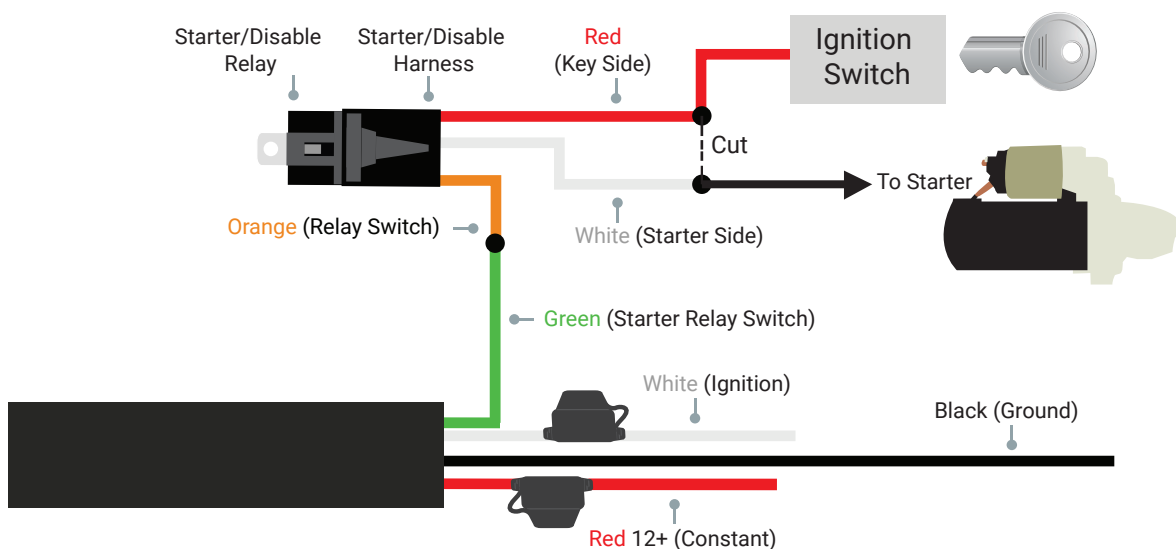

## Unit Wire Color Code

Red = Power  
 Black = Ground  
 White = Ignition  
 Blue = Input 1  
 Orange = Input 2  
 Green = Starter Disable

Brown = Output 1  
 Yellow = Output 2  
 Green\Black = Serial Output  
 Blue\Black = Serial Input  
 White\Blue = 1-Bit Bus Data Line  
 Pink = ADC Input

## Relay Harness Wire Color Code

Red = Key Side  
 White = Starter Side  
 Orange = Relay Switch

# Optional digital input

If the wires below are connectorized simply plug it in the two connectors  
 Blue / White wires may come with connecting clamps.

1. Connect the White/Blue or White/Teal wire (1-Bit Data) on the wiring harness to the grey wire on the Key Fob.
2. Connect the black wire paired with the White/Blue or White/Teal wire on the wiring harness to the black wire on the Key Fob.

# Mounting the Driver ID kit

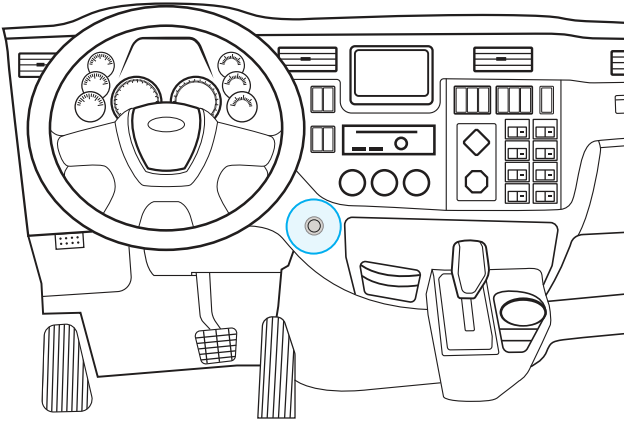

**Choose a convenient location in the vehicle** where the key fob reader is easily accessible. Under or on the vehicle dash is ideal.

1. Drill a 1/2 inch hole and pass the key fob reader wires through, fastening the two reader washers firmly in place. NOTE: Use your best judgment when mounting the key fob reader. Exercise caution when drilling anywhere in a vehicle.

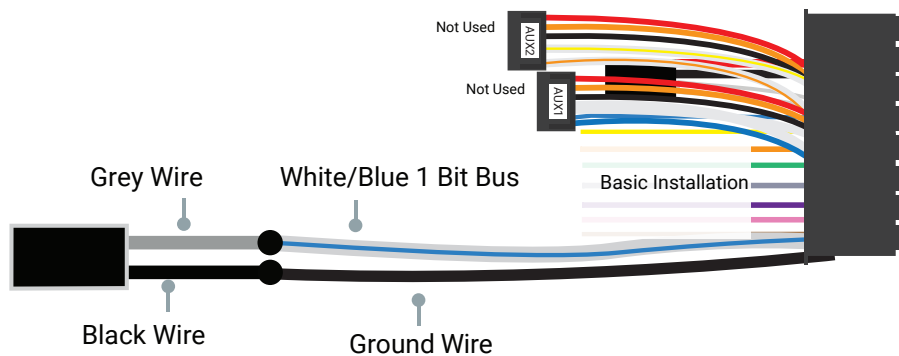
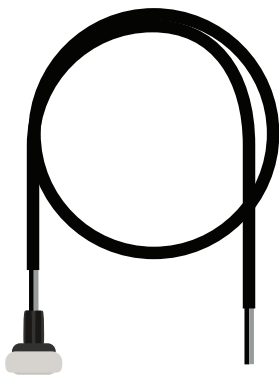

## Connecting the key fob

If the wires below are connectorized simply plug it in the two connectors  
Blue and White wires may come with connecting clamps

1. Connect the **white /blue** wire (1-Bit Data) on the wiring harness to the grey wire on the Key Fob.
2. Connect the Black wire paired with the FOB to the Ground wire on the harness.

# Mounting the Driver Buzzer

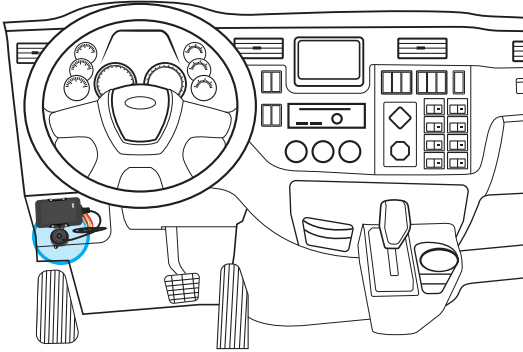

Choose a convenient location in the vehicle, where the Driver Buzzer can easily reach the device's power harness.

Using double-sided tape or other adhesive (not provided), attach the buzzer to a clean, flat surface adjacent to the device. Make sure the buzzer is not blocking any heat vents or otherwise interfering with the normal operation of the vehicle.

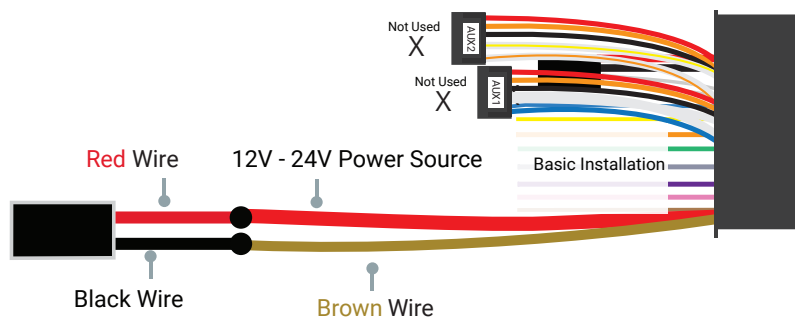
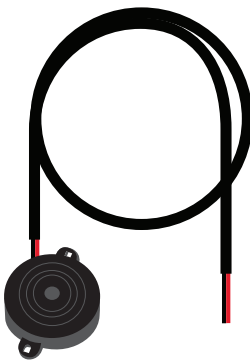

# Connecting the Driver Buzzer

1. Connect a positive 12V-24V power wire on the wiring harness to the **Red** wire on the Driver Buzzer.
2. Connect the **Brown** wire on the wiring harness to the **Black** wire on the Driver Buzzer.



## Download the Zonar App



Scan QR for Apple iOS Devices



Scan QR for Google Devices

If you are new to Zonar, make sure to check your email inbox for an email from [emailverification@fleetsimplified.com](mailto:emailverification@fleetsimplified.com) confirming your login credentials.



### Phone

866-261-8571



### Support

24 hours a day, 7 days a week



### E-Mail

[customercare@zonarsystems.com](mailto:customercare@zonarsystems.com)

Zonar systems and affiliate entities provide installation guides for their GPS tracking devices. Incorrect handling and installation of GPS tracking devices could result in damage to the vehicle, the device, or the installer. Zonar systems and affiliate entities hereby disclaim any and all liability for all damages, losses, expenses, and costs occurring as the result of (or in association with) the installation of these devices by the customer or others.